

# SEQUENCE® 2-Chamber Surface Skimmer

Efficiency counts in every aspect of your pond system. Below is an ideal equipment layout for water exchanges utilizing a bottom drain, two-chamber surface skimmer and an external pump!

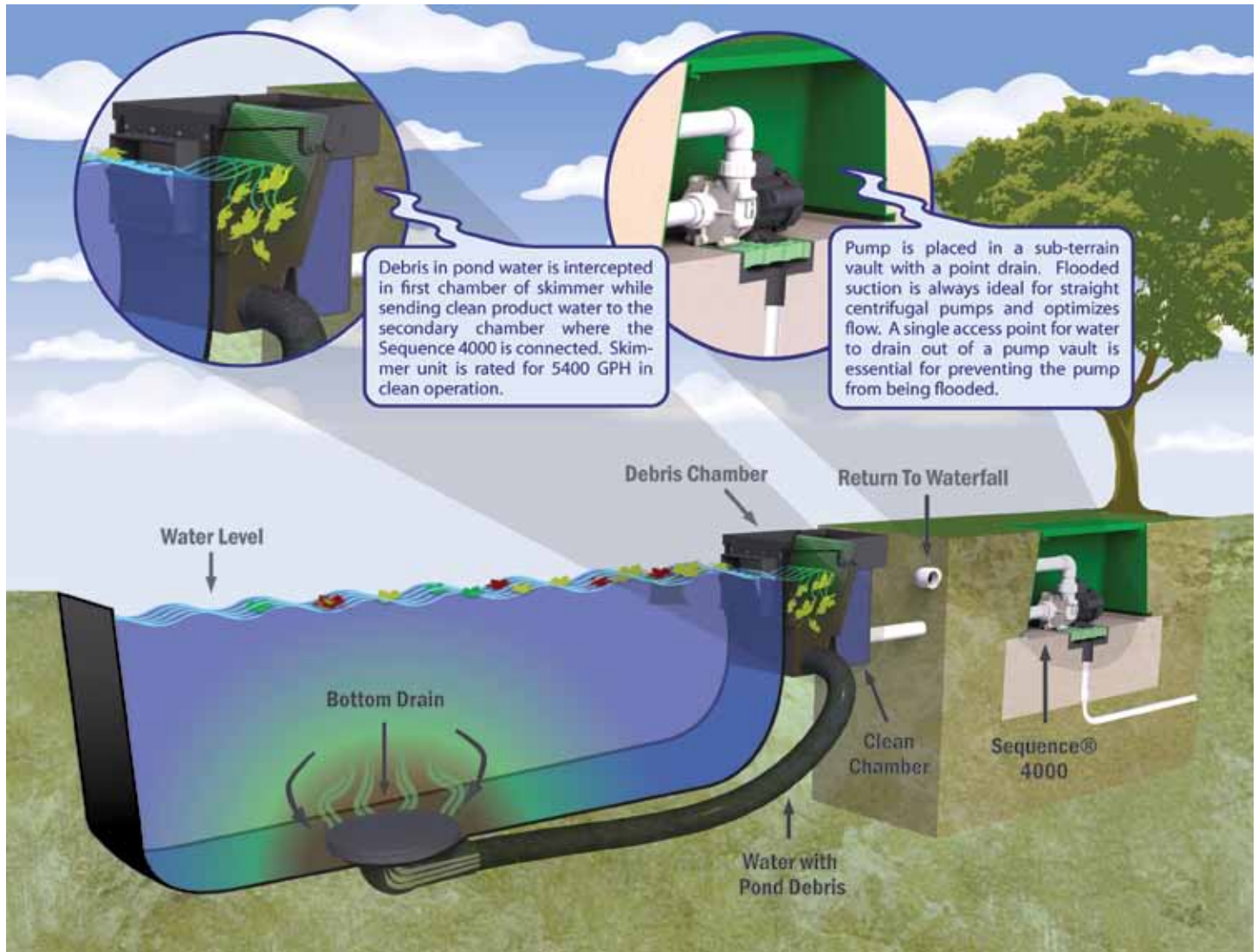

## ■ Benefits of the Surface Skimmer:

- Unique design provides two separate internal chambers
- Debris chamber - Ties bottom drain & surface skimming together while isolating debris
- Clean Chamber - Ties in the external pump with clean water for longevity
- 3" Bottom drain port - Easily connects bottom drain to debris chamber of skimmer

## ■ Benefits of a Skimmer Compared to a Strainer Basket:

- Reduces routine maintenance in a pond system
- Increase overall flow
- Less clogging
- Lowers the exposure to system airlock



Proudly Made in the USA

**Sustainable, Efficient** ©2010 SEQUENCE® PUMPS A DIVISION OF MDM INC.

# SEQUENCE® 2-Chamber Surface Skimmer



## Two-Chamber Surface Skimmer

Integrate a skimmer to your water feature with ease and effectiveness! Intercept debris before it damages your pump! The Sequence® surface skimmer comes equipped with ports to tie into a bottom drain and external pump.

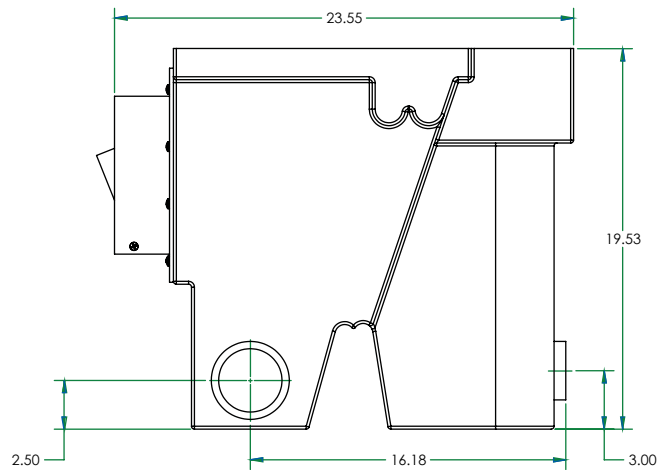
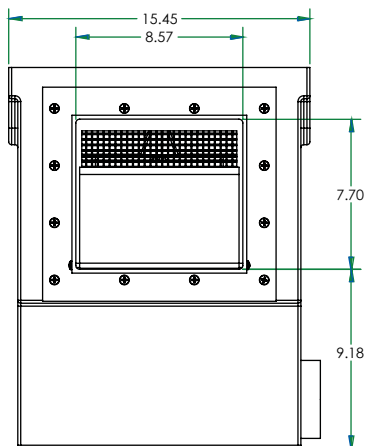
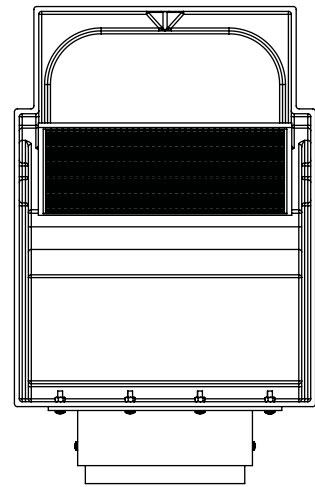

Model Number	Max Flow @ Clean Operation	Flow @ 3" Weir Water Height	Flow @ 4" Weir Water Height & Bottom Drain	Materials Of Construction	Weight
SKM-5600	*5600 GPH	5520 GPH	5600 GPH	Polyethylene	13 LBS
SKM-EXT	*5600 GPH	5520 GPH	5600 GPH	Polyethylene	8 LBS

\* Max flow based on tests with inlet-weir dimensions of 8" width and 4" water height



Proudly Made in the USA

**Sustainable, Efficient** ©2010 SEQUENCE® PUMPS A DIVISION OF MDM INC.